

LM78LXX Series

3-Terminal Positive Regulators

General Description

The LM78LXX series of three terminal positive regulators is available with several fixed output voltages making them useful in a wide range of applications. When used as a zener diode/resistor combination replacement, the LM78LXX usually results in an effective output impedance improvement of two orders of magnitude, and lower quiescent current. These regulators can provide local on card regulation, eliminating the distribution problems associated with single point regulation. The voltages available allow the LM78LXX to be used in logic systems, instrumentation, HiFi, and other solid state electronic equipment.

The LM78LXX is available in the plastic TO-92 (Z) package, the plastic SO-8 (M) package and a chip sized package (8-Bump micro SMD) using National's micro SMD package technology. With adequate heat sinking the regulator can deliver 100 mA output current. Current limiting is included to limit the peak output current to a safe value. Safe area pro-

tection for the output transistors is provided to limit internal power dissipation. If internal power dissipation becomes too high for the heat sinking provided, the thermal shutdown circuit takes over preventing the IC from overheating.

Features

- LM78L05 in micro SMD package
- Output voltage tolerances of $\pm 5\%$ over the temperature range
- Output current of 100 mA
- Internal thermal overload protection
- Output transistor safe area protection
- Internal short circuit current limit
- Available in plastic TO-92 and plastic SO-8 low profile packages
- No external components
- Output voltages of 5.0V, 6.2V, 8.2V, 9.0V, 12V, 15V

Connection Diagrams

**SO-8 Plastic (M)
(Narrow Body)**

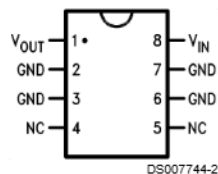

Top View

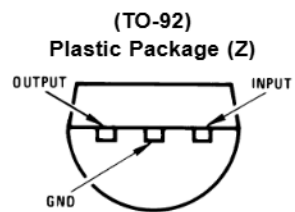

Bottom View

8-Bump micro SMD

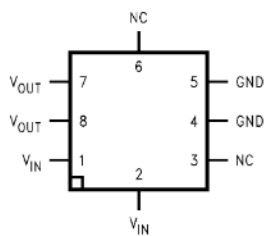

**Top View
(Bump Side Down)**

micro SMD Marking Orientation

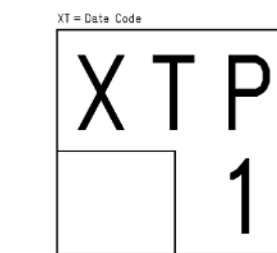

Top View

Absolute Maximum Ratings (Note 1)

If Military/Aerospace specified devices are required, please contact the National Semiconductor Sales Office/Distributors for availability and specifications.

| | |
|----------------------------|--------------------|
| Power Dissipation (Note 5) | Internally Limited |
| Input Voltage | 35V |
| Storage Temperature | -65°C to +150°C |

Operating Junction Temperature

SO-8

0°C to 125°C

micro SMD

-40°C to 85°C

Soldering Information

Infrared or Convection (20 sec.)

235°C

Wave Soldering (10 sec.)

260°C (lead time)

ESD Susceptibility (Note 2)

1kV

LM78LXX Electrical Characteristics

Limits in standard typeface are for $T_J = 25^\circ\text{C}$, **Bold typeface applies over 0°C to 125°C for SO-8 package and -40°C to 85°C for micro SMD package.** Limits are guaranteed by production testing or correlation techniques using standard Statistical Quality Control (SQC) methods. Unless otherwise specified: $I_O = 40\text{ mA}$, $C_I = 0.33\text{ }\mu\text{F}$, $C_O = 0.1\text{ }\mu\text{F}$.

LM78L05Unless otherwise specified, $V_{IN} = 10\text{V}$

| Symbol | Parameter | Conditions | Min | Typ | Max | Units |
|--|---|---|-------------|-------|-------------|----------------------------|
| V_O | Output Voltage | | 4.8 | 5 | 5.2 | V |
| | | $7\text{V} \leq V_{IN} \leq 20\text{V}$ $1\text{ mA} \leq I_O \leq 40\text{ mA}$ (Note 3) | 4.75 | | 5.25 | |
| | | $1\text{ mA} \leq I_O \leq 70\text{ mA}$ (Note 3) | 4.75 | | 5.25 | |
| ΔV_O | Line Regulation | $7\text{V} \leq V_{IN} \leq 20\text{V}$ | | 18 | 75 | mV |
| | | $8\text{V} \leq V_{IN} \leq 20\text{V}$ | | 10 | 54 | |
| ΔV_O | Load Regulation | $1\text{ mA} \leq I_O \leq 100\text{ mA}$ | | 20 | 60 | mV |
| | | $1\text{ mA} \leq I_O \leq 40\text{ mA}$ | | 5 | 30 | |
| I_Q | Quiescent Current | | | 3 | 5 | mA |
| ΔI_Q | Quiescent Current Change | $8\text{V} \leq V_{IN} \leq 20\text{V}$ | | | 1.0 | |
| | | $1\text{ mA} \leq I_O \leq 40\text{ mA}$ | | | 0.1 | |
| V_n | Output Noise Voltage | $f = 10\text{ Hz to }100\text{ kHz}$ (Note 4) | | 40 | | μV |
| $\frac{\Delta V_{IN}}{\Delta V_{OUT}}$ | Ripple Rejection | $f = 120\text{ Hz}$ $8\text{V} \leq V_{IN} \leq 16\text{V}$ | 47 | 62 | | dB |
| I_{PK} | Peak Output Current | | | 140 | | mA |
| $\frac{\Delta V_O}{\Delta T}$ | Average Output Voltage Tempco | $I_O = 5\text{ mA}$ | | -0.65 | | $\text{mV}/^\circ\text{C}$ |
| $V_{IN}(\text{Min})$ | Minimum Value of Input Voltage Required to Maintain Line Regulation | | | 6.7 | 7 | V |
| θ_{JA} | Thermal Resistance (8-Bump micro SMD) | | | 230.9 | | $^\circ\text{C}/\text{W}$ |

LM78L62ACUnless otherwise specified, $V_{IN} = 12\text{V}$

| Symbol | Parameter | Conditions | Min | Typ | Max | Units |
|--------------|-----------------|---|------------|-----|------------|-------|
| V_O | Output Voltage | | 5.95 | 6.2 | 6.45 | V |
| | | $8.5\text{V} \leq V_{IN} \leq 20\text{V}$ $1\text{ mA} \leq I_O \leq 40\text{ mA}$ (Note 3) | 5.9 | | 6.5 | |
| | | $1\text{ mA} \leq I_O \leq 70\text{ mA}$ (Note 3) | 5.9 | | 6.5 | |
| ΔV_O | Line Regulation | $8.5\text{V} \leq V_{IN} \leq 20\text{V}$ | | 65 | 175 | mV |
| | | $9\text{V} \leq V_{IN} \leq 20\text{V}$ | | 55 | 125 | |
| ΔV_O | Load Regulation | $1\text{ mA} \leq I_O \leq 100\text{ mA}$ | | 13 | 80 | mV |
| | | $1\text{ mA} \leq I_O \leq 40\text{ mA}$ | | 6 | 40 | |

LM78L62AC (Continued)Unless otherwise specified, $V_{IN} = 12V$

| Symbol | Parameter | Conditions | Min | Typ | Max | Units |
|--|---|---|-----|-------|------------|----------------|
| I_Q | Quiescent Current | | | 2 | 5.5 | mA |
| ΔI_Q | Quiescent Current Change | $8V \leq V_{IN} \leq 20V$ $1 mA \leq I_O \leq 40 mA$ | | | 1.5 0.1 | |
| V_n | Output Noise Voltage | $f = 10 Hz$ to 100 kHz (Note 4) | | 50 | | μV |
| $\frac{\Delta V_{IN}}{\Delta V_{OUT}}$ | Ripple Rejection | $f = 120 Hz$ $10V \leq V_{IN} \leq 20V$ | 40 | 46 | | dB |
| I_{PK} | Peak Output Current | | | 140 | | mA |
| $\frac{\Delta V_O}{\Delta T}$ | Average Output Voltage Tempco | $I_O = 5 mA$ | | -0.75 | | $mV/^{\circ}C$ |
| $V_{IN} (Min)$ | Minimum Value of Input Voltage Required to Maintain Line Regulation | | | 7.9 | | V |

LM78L82ACUnless otherwise specified, $V_{IN} = 14V$

| Symbol | Parameter | Conditions | Min | Typ | Max | Units |
|--|---|--|------|------|------------|----------------|
| V_O | Output Voltage | | 7.87 | 8.2 | 8.53 | V |
| | | $11V \leq V_{IN} \leq 23V$ $1 mA \leq I_O \leq 40 mA$ (Note 3) | 7.8 | | 8.6 | |
| | | $1 mA \leq I_O \leq 70 mA$ (Note 3) | 7.8 | | 8.6 | |
| ΔV_O | Line Regulation | $11V \leq V_{IN} \leq 23V$ | | 80 | 175 | mV |
| | | $12V \leq V_{IN} \leq 23V$ | | 70 | 125 | |
| ΔV_O | Load Regulation | $1 mA \leq I_O \leq 100 mA$ | | 15 | 80 | |
| | | $1 mA \leq I_O \leq 40 mA$ | | 8 | 40 | |
| I_Q | Quiescent Current | | | 2 | 5.5 | mA |
| ΔI_Q | Quiescent Current Change | $12V \leq V_{IN} \leq 23V$ $1 mA \leq I_O \leq 40 mA$ | | | 1.5 0.1 | |
| V_n | Output Noise Voltage | $f = 10 Hz$ to 100 kHz (Note 4) | | 60 | | μV |
| $\frac{\Delta V_{IN}}{\Delta V_{OUT}}$ | Ripple Rejection | $f = 120 Hz$ $12V \leq V_{IN} \leq 22V$ | 39 | 45 | | dB |
| I_{PK} | Peak Output Current | | | 140 | | mA |
| $\frac{\Delta V_O}{\Delta T}$ | Average Output Voltage Tempco | $I_O = 5 mA$ | | -0.8 | | $mV/^{\circ}C$ |
| $V_{IN} (Min)$ | Minimum Value of Input Voltage Required to Maintain Line Regulation | | | 9.9 | | V |

LM78L09ACUnless otherwise specified, $V_{IN} = 15V$

| Symbol | Parameter | Conditions | Min | Typ | Max | Units |
|--------|----------------|--|------|-----|------|-------|
| V_O | Output Voltage | | 8.64 | 9.0 | 9.36 | V |
| | | $11.5V \leq V_{IN} \leq 24V$ $1 mA \leq I_O \leq 40 mA$ (Note 3) | 8.55 | | 9.45 | |
| | | $1 mA \leq I_O \leq 70 mA$ (Note 3) | 8.55 | | 9.45 | |

LM78L09AC (Continued)Unless otherwise specified, $V_{IN} = 15V$

| Symbol | Parameter | Conditions | Min | Typ | Max | Units |
|--|---|--|-----|------|------------|---------|
| ΔV_O | Line Regulation | $11.5V \leq V_{IN} \leq 24V$ | | 100 | 200 | mV |
| | | $13V \leq V_{IN} \leq 24V$ | | 90 | 150 | |
| ΔV_O | Load Regulation | $1 mA \leq I_O \leq 100 mA$ | | 20 | 90 | mV |
| | | $1 mA \leq I_O \leq 40 mA$ | | 10 | 45 | |
| I_Q | Quiescent Current | | | 2 | 5.5 | mA |
| ΔI_Q | Quiescent Current Change | $11.5V \leq V_{IN} \leq 24V$ | | | 1.5 | |
| | | $1 mA \leq I_O \leq 40 mA$ | | | 0.1 | |
| V_n | Output Noise Voltage | | | 70 | | μV |
| $\frac{\Delta V_{IN}}{\Delta V_{OUT}}$ | Ripple Rejection | $f = 120 Hz$ $15V \leq V_{IN} \leq 25V$ | 38 | 44 | | dB |
| I_{PK} | Peak Output Current | | | 140 | | mA |
| $\frac{\Delta V_O}{\Delta T}$ | Average Output Voltage Tempco | $I_O = 5 mA$ | | -0.9 | | mV/°C |
| $V_{IN} (Min)$ | Minimum Value of Input Voltage Required to Maintain Line Regulation | | | 10.7 | | V |

LM78L12ACUnless otherwise specified, $V_{IN} = 19V$

| Symbol | Parameter | Conditions | Min | Typ | Max | Units |
|--|---|--|-------------|------|-------------|---------|
| V_O | Output Voltage | | 11.5 | 12 | 12.5 | V |
| | | $14.5V \leq V_{IN} \leq 27V$ $1 mA \leq I_O \leq 40 mA$ (Note 3) | 11.4 | | 12.6 | |
| | | $1 mA \leq I_O \leq 70 mA$ (Note 3) | 11.4 | | 12.6 | |
| ΔV_O | Line Regulation | $14.5V \leq V_{IN} \leq 27V$ | | 30 | 180 | mV |
| | | $16V \leq V_{IN} \leq 27V$ | | 20 | 110 | |
| ΔV_O | Load Regulation | $1 mA \leq I_O \leq 100 mA$ | | 30 | 100 | mV |
| | | $1 mA \leq I_O \leq 40 mA$ | | 10 | 50 | |
| I_Q | Quiescent Current | | | 3 | 5 | mA |
| ΔI_Q | Quiescent Current Change | $16V \leq V_{IN} \leq 27V$ | | | 1 | |
| | | $1 mA \leq I_O \leq 40 mA$ | | | 0.1 | |
| V_n | Output Noise Voltage | | | 80 | | μV |
| $\frac{\Delta V_{IN}}{\Delta V_{OUT}}$ | Ripple Rejection | $f = 120 Hz$ $15V \leq V_{IN} \leq 25$ | 40 | 54 | | dB |
| I_{PK} | Peak Output Current | | | 140 | | mA |
| $\frac{\Delta V_O}{\Delta T}$ | Average Output Voltage Tempco | $I_O = 5 mA$ | | -1.0 | | mV/°C |
| $V_{IN} (Min)$ | Minimum Value of Input Voltage Required to Maintain Line Regulation | | | 13.7 | 14.5 | V |

LM78L15ACUnless otherwise specified, $V_{IN} = 23V$

| Symbol | Parameter | Conditions | Min | Typ | Max | Units |
|--|---|--|--------------|------|--------------|---------|
| V_O | Output Voltage | | 14.4 | 15.0 | 15.6 | V |
| | | $17.5V \leq V_{IN} \leq 30V$ $1 mA \leq I_O \leq 40 mA$ (Note 3) | 14.25 | | 15.75 | |
| | | $1 mA \leq I_O \leq 70 mA$ (Note 3) | 14.25 | | 15.75 | |
| ΔV_O | Line Regulation | $17.5V \leq V_{IN} \leq 30V$ | | 37 | 250 | mV |
| | | $20V \leq V_{IN} \leq 30V$ | | 25 | 140 | |
| ΔV_O | Load Regulation | $1 mA \leq I_O \leq 100 mA$ | | 35 | 150 | mV |
| | | $1 mA \leq I_O \leq 40 mA$ | | 12 | 75 | |
| I_Q | Quiescent Current | | | 3 | 5 | mA |
| ΔI_Q | Quiescent Current Change | $20V \leq V_{IN} \leq 30V$ | | | 1 | |
| | | $1 mA \leq I_O \leq 40 mA$ | | | 0.1 | |
| V_n | Output Noise Voltage | | | 90 | | μV |
| $\frac{\Delta V_{IN}}{\Delta V_{OUT}}$ | Ripple Rejection | $f = 120 Hz$ $18.5V \leq V_{IN} \leq 28.5V$ | 37 | 51 | | dB |
| I_{PK} | Peak Output Current | | | 140 | | mA |
| $\frac{\Delta V_O}{\Delta T}$ | Average Output Voltage Tempco | $I_O = 5 mA$ | | -1.3 | | mV/°C |
| $V_{IN} (Min)$ | Minimum Value of Input Voltage Required to Maintain Line Regulation | | | 16.7 | 17.5 | V |

Note 1: Absolute Maximum Ratings indicate limits beyond which damage to the device may occur. Electrical specifications do not apply when operating the device outside of its stated operating conditions.

Note 2: Human body model, 1.5 k Ω in series with 100 pF.

Note 3: Power dissipation $\leq 0.75W$.

Note 4: Recommended minimum load capacitance of 0.01 μF to limit high frequency noise.

Note 5: Typical thermal resistance values for the packages are:

Z Package: $\theta_{JC} = 60 ^\circ C/W$, $\theta_{JA} = 230 ^\circ C/W$

M Package: $\theta_{JA} = 180 ^\circ C/W$

micro SMD Package: $\theta_{JA} = 230.9^\circ C/W$

Typical Performance Characteristics

Maximum Average Power Dissipation (Z Package)

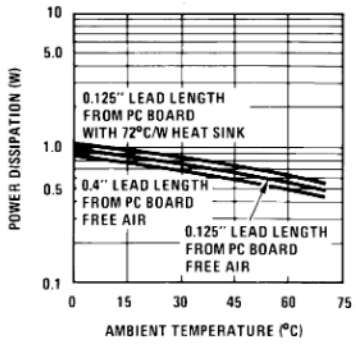

Peak Output Current

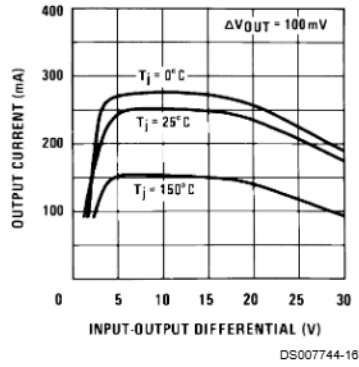

Dropout Voltage

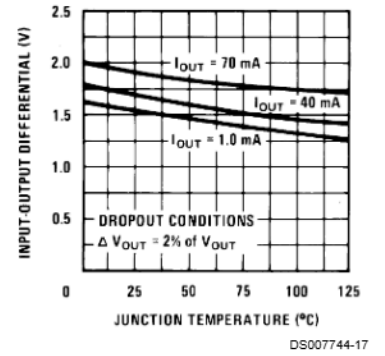

Ripple Rejection

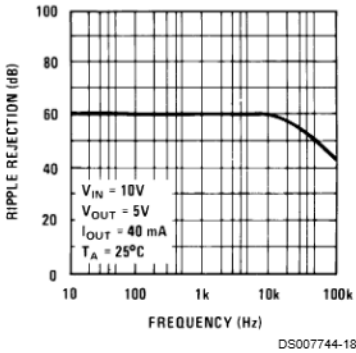

Output Impedance

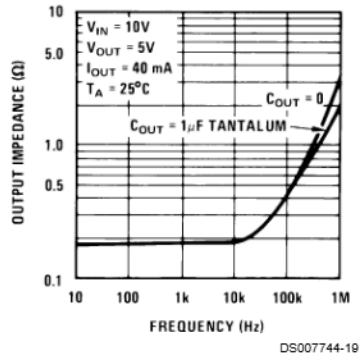

Quiescent Current

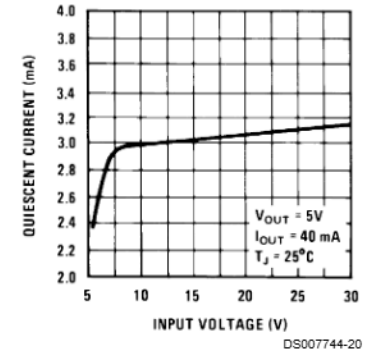

Quiescent Current

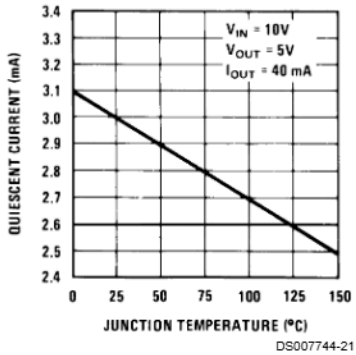

Equivalent Circuit

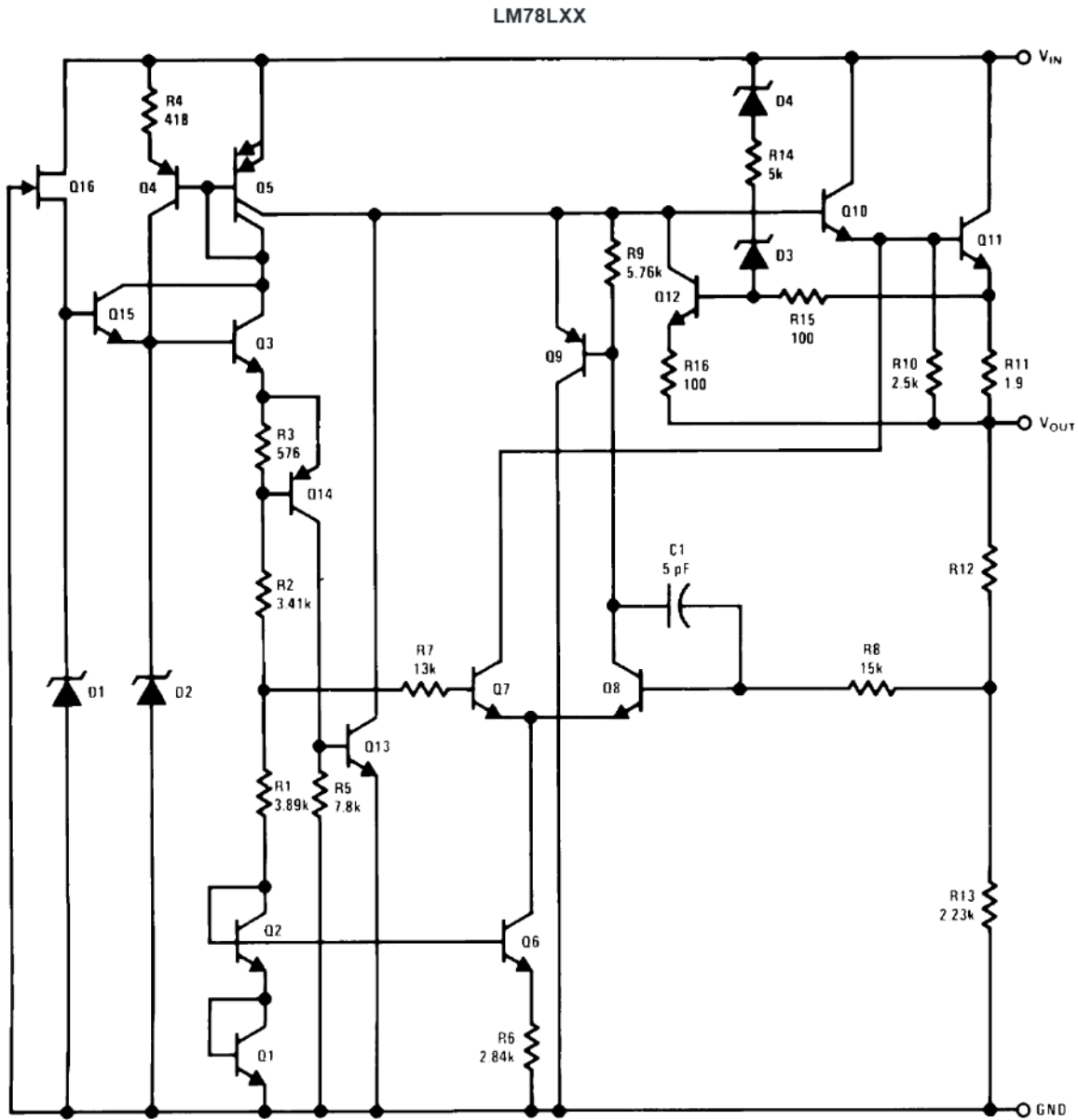

DS007744-7

Typical Applications

Fixed Output Regulator

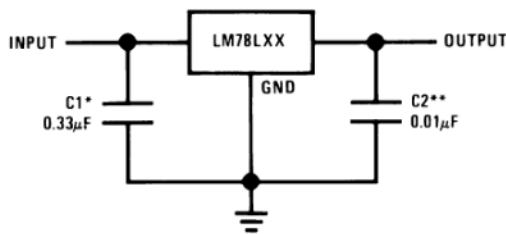

DS007744-8

*Required if the regulator is located more than 3" from the power supply filter.

**See (Note 4) in the electrical characteristics table.

Typical Applications (Continued)

Adjustable Output Regulator

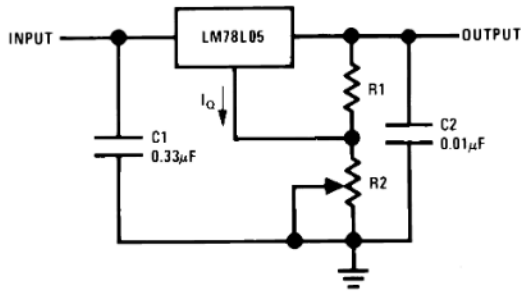

DS007744-9

$$V_{OUT} = 5V + (5V/R1 + I_Q) R2$$

$$5V/R1 > 3 I_Q, \text{ load regulation } (L_r) \approx [(R1 + R2)/R1] (L_r \text{ of LM78L05})$$

Current Regulator

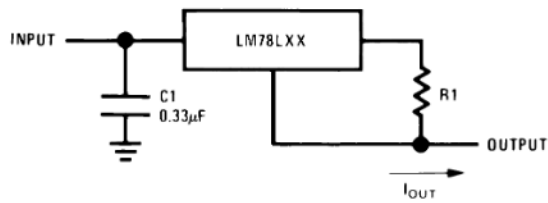

DS007744-10

$$I_{OUT} = (V_{OUT}/R1) + I_Q$$

> $I_Q = 1.5 \text{ mA}$ over line and load changes

5V, 500 mA Regulator with Short Circuit Protection

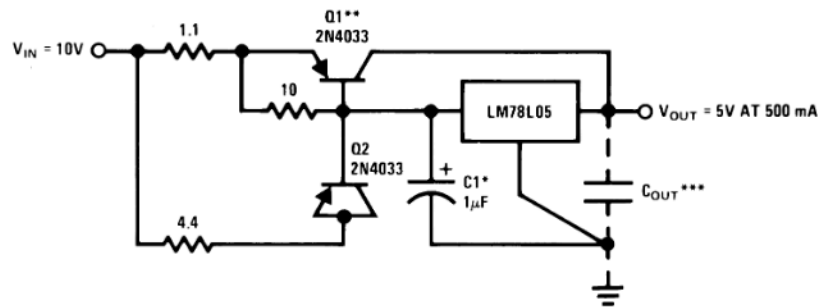

DS007744-11

*Solid tantalum.
 **Heat sink Q1.
 ***Optional: Improves ripple rejection and transient response.
 Load Regulation: 0.6% $0 \leq I_L \leq 250 \text{ mA}$ pulsed with $t_{ON} = 50 \text{ ms}$.

±15V, 100 mA Dual Power Supply

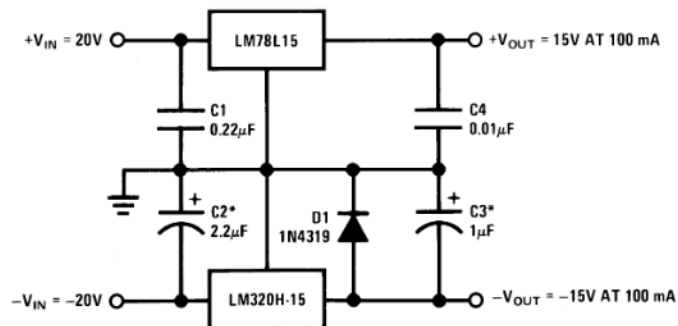

DS007744-12

*Solid tantalum.

Typical Applications (Continued)

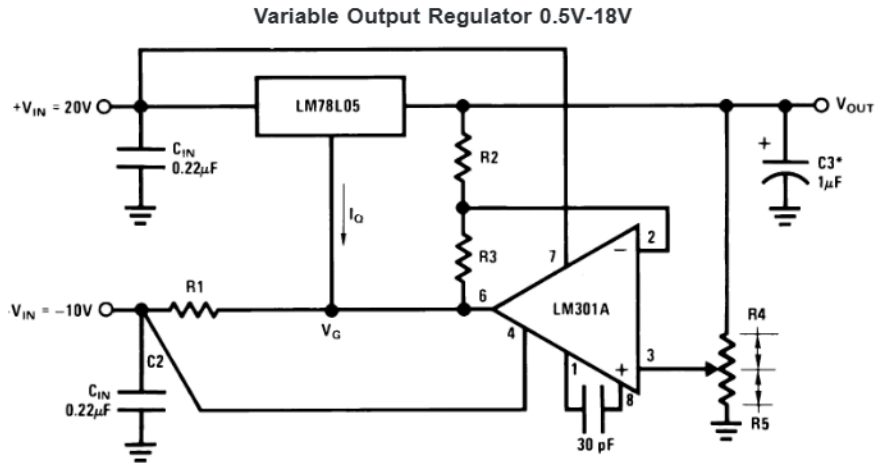

DS007744-13

*Solid tantalum.

$V_{OUT} = V_G + 5V$, $R1 = (-V_{IN}/I_Q \text{ LM78L05})$

$V_{OUT} = 5V (R2/R4)$ for $(R2 + R3) = (R4 + R5)$

A 0.5V output will correspond to $(R2/R4) = 0.1$ $(R3/R4) = 0.9$

Physical Dimensions inches (millimeters) unless otherwise noted

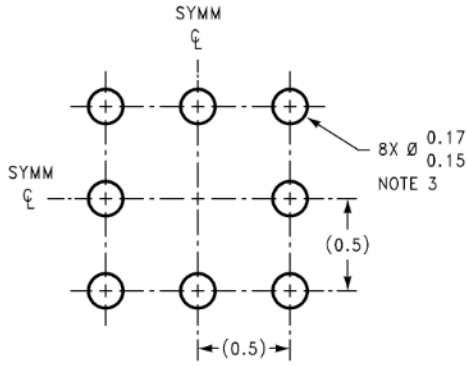

LAND PATTERN RECOMMENDATION

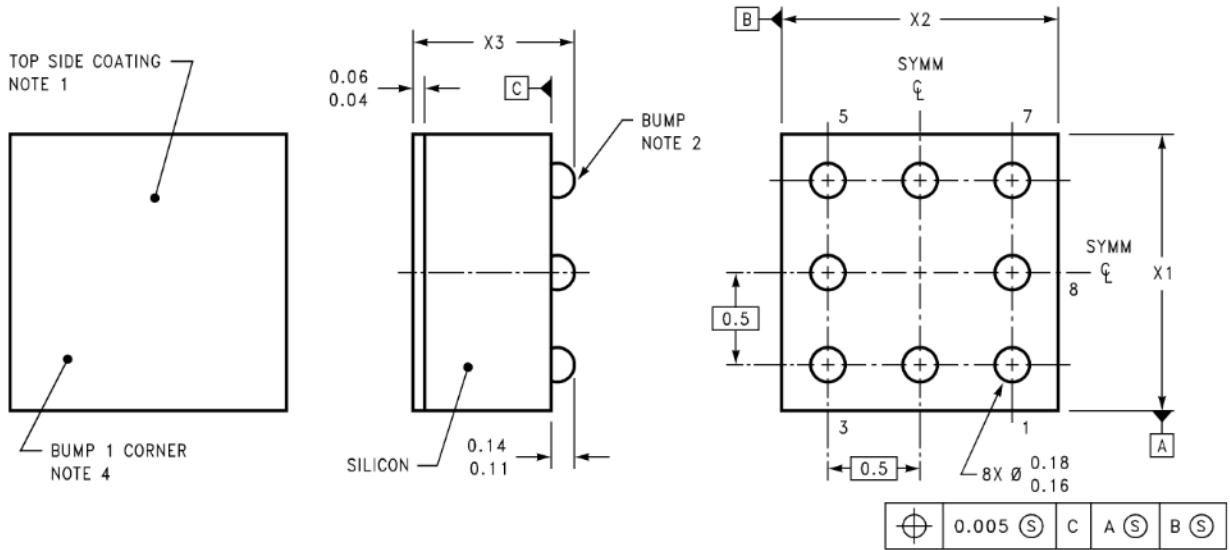

DIMENSIONS ARE IN MILLIMETERS

BPA08XXX (REV A)

NOTES: UNLESS OTHERWISE SPECIFIED

1. EPOXY COATING
2. 63Sn/37Pb EUTECTIC BUMP
3. RECOMMEND NON-SOLDER MASK DEFINED LANDING PAD.
4. PIN 1 IS ESTABLISHED BY LOWER LEFT CORNER WITH RESPECT TO TEXT ORIENTATION. REMAINING PINS ARE NUMBERED COUNTERCLOCKWISE.
5. XXX IN DRAWING NUMBER REPRESENTS PACKAGE SIZE VARIATION WHERE X_1 IS PACKAGE WIDTH, X_2 IS PACKAGE LENGTH AND X_3 IS PACKAGE HEIGHT.
6. REFERENCE JEDEC REGISTRATION MO-211, VARIATION BC.

8-Bump micro SMD
Order Number LM78L05IBP or LM78L05IBPX
NS Package Number BPA08AAA
 $X_1 = 1.285$ $X_2 = 1.285$ $X_3 = 0.7$

Notes

LIFE SUPPORT POLICY

NATIONAL'S PRODUCTS ARE NOT AUTHORIZED FOR USE AS CRITICAL COMPONENTS IN LIFE SUPPORT DEVICES OR SYSTEMS WITHOUT THE EXPRESS WRITTEN APPROVAL OF THE PRESIDENT AND GENERAL COUNSEL OF NATIONAL SEMICONDUCTOR CORPORATION. As used herein:

1. Life support devices or systems are devices or systems which, (a) are intended for surgical implant into the body, or (b) support or sustain life, and whose failure to perform when properly used in accordance with instructions for use provided in the labeling, can be reasonably expected to result in a significant injury to the user.
2. A critical component is any component of a life support device or system whose failure to perform can be reasonably expected to cause the failure of the life support device or system, or to affect its safety or effectiveness.



National Semiconductor Corporation
Americas
Tel: 1-800-272-9959
Fax: 1-800-737-7018
Email: support@nsc.com

www.national.com

National Semiconductor Europe
Fax: +49 (0) 1 80-530 85 86
Email: europe.support@nsc.com
Deutsch Tel: +49 (0) 1 80-530 85 85
English Tel: +49 (0) 1 80-532 78 32
Français Tel: +49 (0) 1 80-532 93 58
Italiano Tel: +49 (0) 1 80-534 16 80

National Semiconductor Asia Pacific Customer Response Group
Tel: 65-2544466
Fax: 65-2504466
Email: sea.support@nsc.com

National Semiconductor Japan Ltd.
Tel: 81-3-5639-7560
Fax: 81-3-5639-7507