

SN54LS320, SN54LS321, SN74LS320, SN74LS321 CRYSTAL-CONTROLLED OSCILLATORS

SDLS158 – DECEMBER 1978 – REVISED MARCH 1988

'LS320

- Crystal-Controlled Oscillator Operation from 1 MHz to 20 MHz
- 2-Phase Driver Outputs

'LS321

- Similar to 'LS320 But Includes f/2 and f/4 Count-Down Outputs

description

The 'LS320 is a crystal-controlled oscillator/clock driver. It features complementary standard and high-current driver outputs. A synchronization flip-flop is included.

The driver outputs, F' and \bar{F}' have very-low impedance and can be used to drive highly capacitive TTL-level lines. If the driver outputs are not used, then the VCC' terminal can be left open.

The 'LS321 is identical to the 'LS320 except it additionally features two count-down outputs, F/2 and F/4.

These circuits were designed for crystal control of frequency and capacitive control is not recommended. If a fundamental crystal is used, an inductor of 5 to 160 μ H is required to be connected between the tank 1 and tank 2 inputs. †

Interaction of the driver outputs with the other outputs limits useful frequencies as shown in the frequency-limits table.

The SN54LS320 and SN54LS321 are characterized for operation over the full military temperature range of -55°C to 125°C. The SN74LS320 and SN74LS321 are characterized for operation from 0°C to 70°C.

logic symbols†

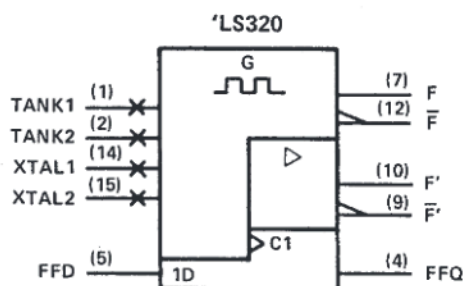

SN54LS320 . . . J OR W PACKAGE
SN74LS320 . . . N PACKAGE
(TOP VIEW)

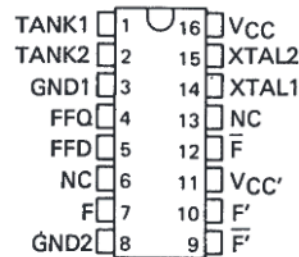

SN54LS321 . . . J PACKAGE
SN74LS321 . . . N PACKAGE
(TOP VIEW)

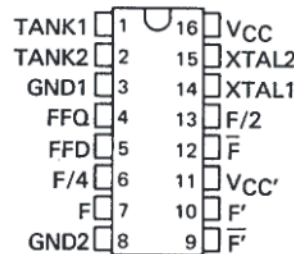

NC – No internal connection.

For chip carrier information,
contact the factory.

FREQUENCY LIMITS

OUTPUTS IN USE	VCC	VCC'	f _{max}
Driver outputs only	5 V	5 V	20 MHz
Other outputs only	5 V	Open	20 MHz
Driver and any other outputs	5 V	5 V	10 MHz

'LS321

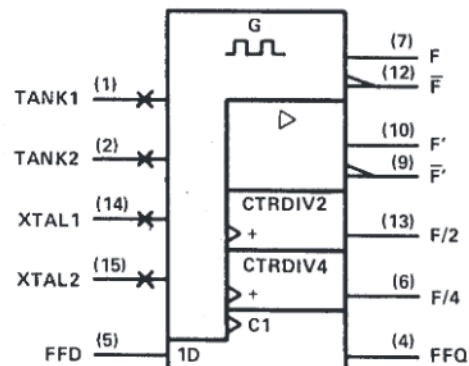

†The value of the inductor is selected from the graph in Figure 2. Use the next higher standard inductor value if the selected value is not available. If a third overtone crystal is used, a tuned tank is necessary. The center frequency of the tuned tank is determined by the equation $f = \frac{1}{2} \pi \sqrt{LC}$.

‡These symbols are in accordance with ANSI/IEEE Std. 91-1984 and IEC Publication 617-12.

SN54LS320, SN54LS321, SN74LS320, SN74LS321 CRYSTAL-CONTROLLED OSCILLATORS

SDLS158 – DECEMBER 1978 – REVISED MARCH 1988

logic diagram (positive logic)

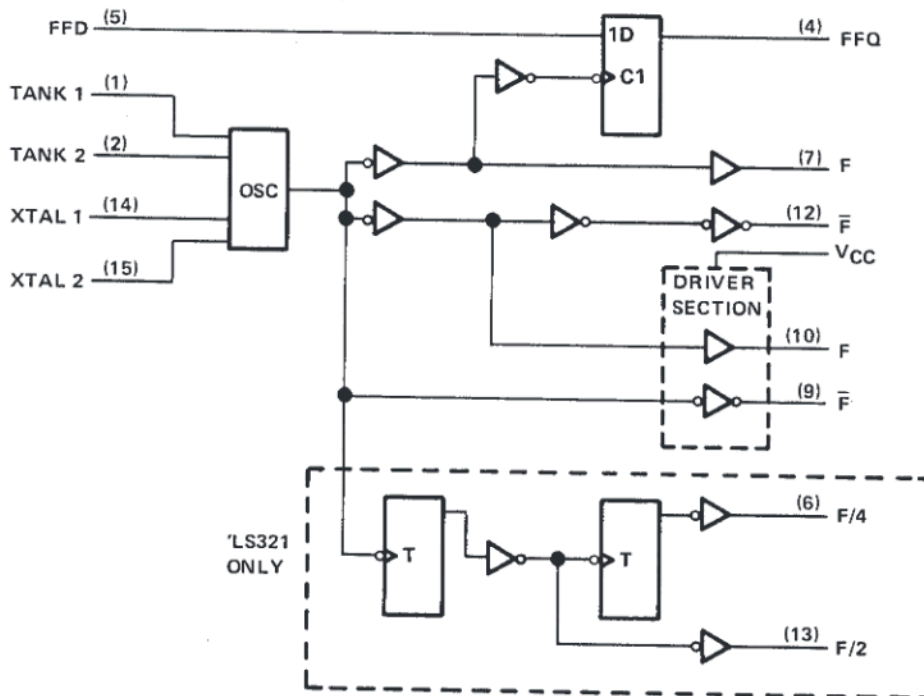

absolute maximum ratings over operating free-air temperature (unless otherwise noted)

Supply voltage, V_{CC} (see Note 1)	7 V
Supply voltage, V_{CC}'	7 V
Input voltage to FFD terminal	-0.5 V to 7 V
Operating free-air temperature range: SN54LS320, SN54LS321	-55°C to 125°C
SN74LS320, SN74LS321	0°C to 70°C
Storage temperature range	-65°C to 150°C

NOTE 1: Voltage values are with respect to network ground terminals.

recommended operating conditions

	SN54LS320 SN54LS321			SN74LS320 SN74LS321			UNIT
	MIN	NOM	MAX	MIN	NOM	MAX	
Supply voltage, V_{CC}	4.5	5	5.5	4.75	5	5.25	V
Supply voltage, V_{CC}'	4.5	5	5.5	4.75	5	5.25	V
High-level output current, I_{OH}	F' or \bar{F}'		-12			-24	mA
	F, \bar{F} , F/2, F/4		-0.4			-0.4	
Low-level output current, I_{OL}	F' or \bar{F}'		12			24	mA
	F, \bar{F} , F/2, F/4		4			8	
Output frequency, f_{out}	F/2 ('LS321)		0.5			10	MHz
	F/4 ('LS321)		0.25			5	
	F or \bar{F}		1			20	
Operating free-air temperature, T_A			-55			125	°C

Input and output schematics are similar to those shown for SN74LS326.



POST OFFICE BOX 655303 • DALLAS, TEXAS 75265

SN54LS320, SN54LS321, SN74LS320, SN74LS321 CRYSTAL-CONTROLLED OSCILLATORS

SDLS158 – DECEMBER 1978 – REVISED MARCH 1988

electrical characteristics over recommended operating free-air temperature range (unless otherwise noted)

PARAMETER	TEST CONDITIONS†	SN54LS320 SN54LS321		SN74LS320 SN74LS321		UNIT		
		MIN	TYP‡	MAX	MIN		TYP‡	MAX
V _{IH} High-level input voltage		2			2	V		
V _{IL} Low-level input voltage				0.7		0.8		
V _{IK} Input clamp voltage	V _{CC} = MIN, V _{CC'} = MIN, I _I = -18 mA			-1.5		-1.5		
V _{OH} High-level output voltage	F', F̄'	V _{CC} = 4.5 V, V _{CC'} = 4.5 V, I _{OH} = -12 mA	2.4	3.3			V	
		V _{CC} = 4.75 V, V _{CC'} = 4.75 V, I _{OH} = -24 mA			2.7	3.3		
	Others	V _{CC} = MIN, V _{IH} = 2 V, I _{OH} = -400 μA	2.4	3.4	2.7	3.4		
V _{OL} Low-level output voltage	F', F̄'	V _{CC} = MIN, V _{CC'} = MIN	I _{OL} = 12 mA	0.25	0.4	0.25	0.4	V
			I _{OL} = 24 mA			0.35	0.5	
	Others	V _{CC} = MIN, V _{IL} = V _{IL} max	I _{OL} = 4 mA	0.25	0.4	0.25	0.4	
			I _{OL} = 8 mA			0.35	0.5	
I _I Input current at maximum input voltage	V _{CC} = MAX, V _I = 7 V			0.1		0.1	mA	
I _{IH} High-level input current	V _{CC} = MAX, V _I = 2.7 V			20		20	μA	
I _{IL} Low-level input current	V _{CC} = MAX, V _I = 0.4 V			-0.4		-0.4	mA	
I _{OS} Short-circuit output current§	V _{CC} = MAX	-20		-100	-20	-100	mA	
I _{CC} Supply current from V _{CC}	V _{CC} = MAX, FFD at GND	'LS320	42	70	42	70	mA	
		'LS321	47	75	47	75		
I _{CC'} Supply current from V _{CC'}	V _{CC} = MAX, V _{CC'} = MAX, FFD at GND		4	8		4	8	mA

† For conditions shown as MIN or MAX, use the appropriate value specified under recommended operating conditions.

‡ All typical values are at V_{CC} = 5 V, V_{CC'} = 5 V, and T_A = 25°C.

§ Not more than one output should be shorted at a time, and duration of the short-circuit should not exceed one second. Outputs F' and F̄' do not have short-circuit protection and these limits do not apply.

switching characteristics, V_{CC} = 5 V, V_{CC'} = 5 V, T_A = 25°C

PARAMETER	OUTPUTS	TEST CONDITIONS†	'LS320			'LS321			UNIT	
			MIN	TYP	MAX	MIN	TYP	MAX		
f _{max} Maximum operating frequency	F/2	C _L = 100 pF	R _L = 667 Ω				10	15	MHz	
	F/4						5	7.5		
	All others			R _L = 2 kΩ	20	30		20		30
t _r Rise time, 1 V to 3 V	F', F'	C _L = 50 pF	R _L = 667 Ω		6	12		6	12	ns
		C _L = 100 pF			7	14		7	14	
		C _L = 200 pF			7	14		7	14	
	Others	C _L = 50 pF	R _L = 2 kΩ		11	22		11	22	
		C _L = 100 pF			25	40		25	40	
		C _L = 200 pF			45	70		45	70	
t _f Fall time, 3 V to 1 V	F', F'	C _L = 50 pF	R _L = 667 Ω		5	10		5	10	ns
		C _L = 100 pF			5	10		5	10	
		C _L = 200 pF			6	12		6	12	
	Others	C _L = 50 pF	R _L = 2 kΩ		6	12		6	12	
		C _L = 100 pF			10	20		10	20	
		C _L = 200 pF			17	30		17	30	

† Load circuits and voltage waveforms are shown in Section 1.



SN54LS320, SN54LS321, SN74LS320, SN74LS321 CRYSTAL-CONTROLLED OSCILLATORS

SDLS158 – DECEMBER 1978 – REVISED MARCH 1988

TYPICAL APPLICATION DATA

The SN54/74LS320 and 'LS321 are crystal-controlled oscillators. Figure 1 shows the device with all required external components.

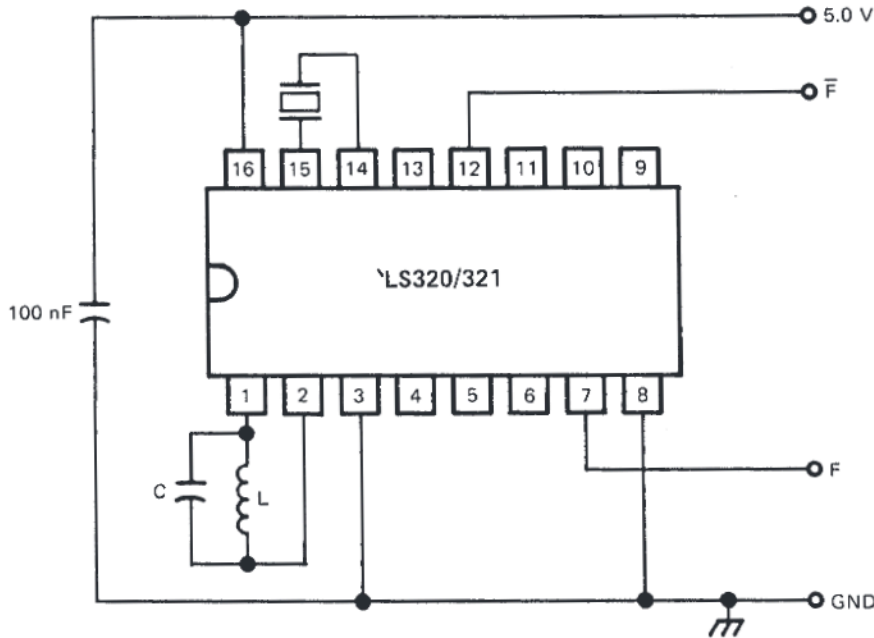

FIGURE 1. CRYSTAL-CONTROLLED OSCILLATOR 'LS320/321

1. Determination of C and L are as follows:
 - a. Inductance L
Select Inductance L according to Figure 2.
 - b. Capacitor C

$$C = C_S - C_P - C_L$$

- Where:
- C_P = parasitic board capacitance
 - C_L = parasitic capacitance of the inductor
 - L = inductance
 - C_S = required capacitance calculated as follows:

$$C_S = \frac{1}{(2 \cdot \pi \cdot f_q)^2 \cdot L}$$

for $f_q > 12$ MHz, $C = 0$ pf

2. Electrical characteristic for the crystal:
The quartz crystal used as a frequency reference should be designed for series mode operation with a resistance in the 20 Ω to 75 Ω range and be capable of a minimum 2 mw power dissipation.
It is recommended to use a tuned tank also for fundamental crystals.

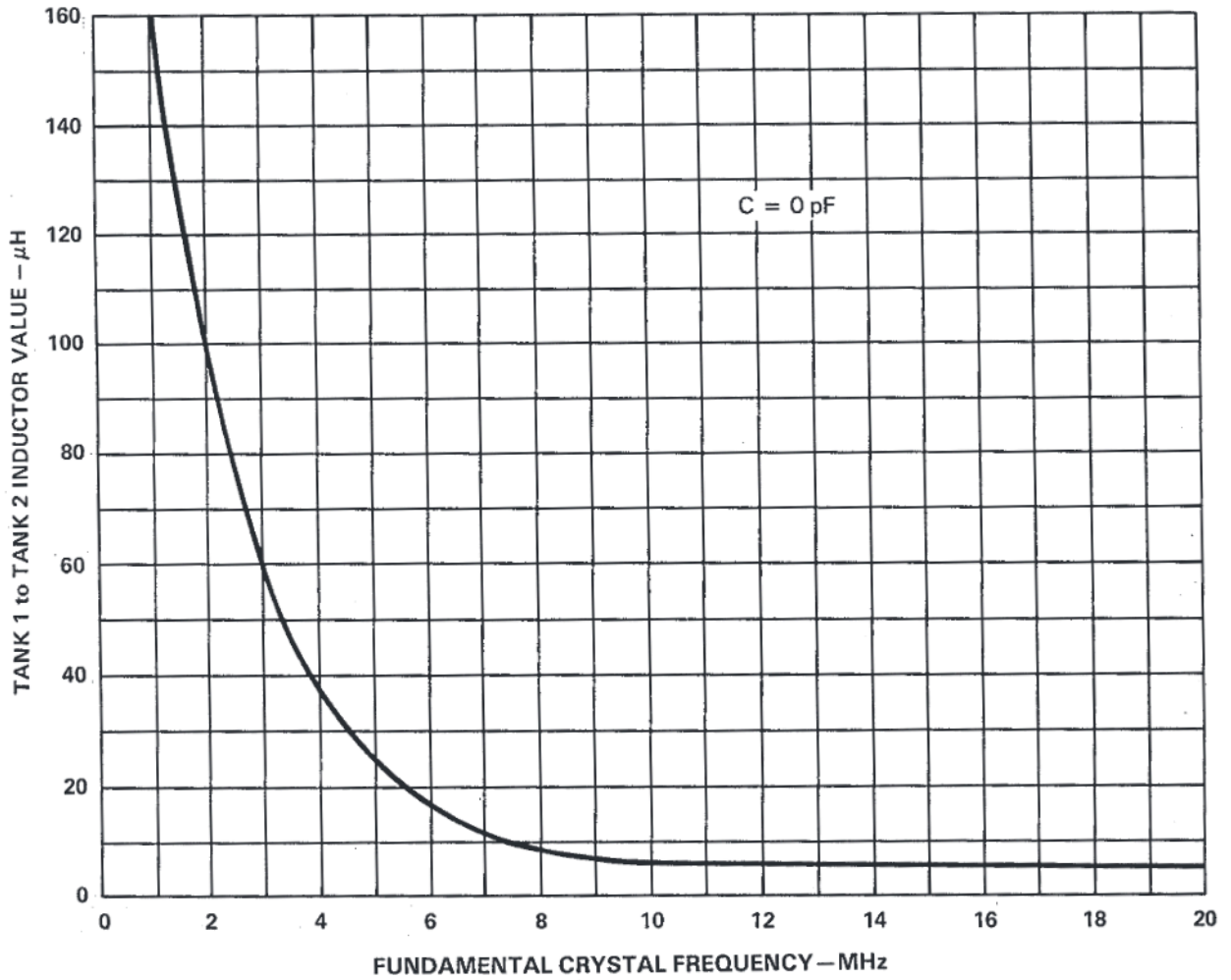

FIGURE 2

IMPORTANT NOTICE

Texas Instruments and its subsidiaries (TI) reserve the right to make changes to their products or to discontinue any product or service without notice, and advise customers to obtain the latest version of relevant information to verify, before placing orders, that information being relied on is current and complete. All products are sold subject to the terms and conditions of sale supplied at the time of order acknowledgement, including those pertaining to warranty, patent infringement, and limitation of liability.

TI warrants performance of its semiconductor products to the specifications applicable at the time of sale in accordance with TI's standard warranty. Testing and other quality control techniques are utilized to the extent TI deems necessary to support this warranty. Specific testing of all parameters of each device is not necessarily performed, except those mandated by government requirements.

CERTAIN APPLICATIONS USING SEMICONDUCTOR PRODUCTS MAY INVOLVE POTENTIAL RISKS OF DEATH, PERSONAL INJURY, OR SEVERE PROPERTY OR ENVIRONMENTAL DAMAGE ("CRITICAL APPLICATIONS"). TI SEMICONDUCTOR PRODUCTS ARE NOT DESIGNED, AUTHORIZED, OR WARRANTED TO BE SUITABLE FOR USE IN LIFE-SUPPORT DEVICES OR SYSTEMS OR OTHER CRITICAL APPLICATIONS. INCLUSION OF TI PRODUCTS IN SUCH APPLICATIONS IS UNDERSTOOD TO BE FULLY AT THE CUSTOMER'S RISK.

In order to minimize risks associated with the customer's applications, adequate design and operating safeguards must be provided by the customer to minimize inherent or procedural hazards.

TI assumes no liability for applications assistance or customer product design. TI does not warrant or represent that any license, either express or implied, is granted under any patent right, copyright, mask work right, or other intellectual property right of TI covering or relating to any combination, machine, or process in which such semiconductor products or services might be or are used. TI's publication of information regarding any third party's products or services does not constitute TI's approval, warranty or endorsement thereof.